

LIEFERUMFANG

POWERPAINTER 90 EXTRA SPRAYPACK - DPPPE	2401275
Basic unit, PowerPainter 90 Extra	-
Airless gun Vector Pro, 1/4", incl. TradeTip 3 nozzle holder, with 4-finger trigger	538040
HP hose DN6, 15 m	9984574
HEA ProTip 517	554517
Integrated toolbox	-
Gun filter white, 1 piece, 50 MA, 0.31 mm MW, medium	34377
Pressure gauge set assy. HEA(MPa)	2383995
EasyGlide, special oil, 118 ml	508619



INNOVATION SINCE 1947

Perfect surfaces and added value are our passion. Bringing colour, protection and function to surfaces is our mission. We dedicate all of our technical expertise to your objects and products, and support you with personal service. Using innovative technologies and highly efficient, reliable and user-friendly solutions, we are constantly setting new standards in surface technology.



wagner-group.com/3plus2

Anyone purchasing a WAGNER paint spraying unit automatically receives a three-year manufacturer's warranty. But we can do more: If you register online, you can extend this warranty for a further two years, free of charge!

HEA TECHNOLOGY

HEA stands for High Efficiency Airless, the innovative nozzle technology revolutionising airless spraying. HEA tips allow the pressure of the spray device to be reduced right down and allow it to work in the low-pressure range (ideally at 80 - 140 bar). The tips can be used with all TradeTip 3 tip holders and WAGNER devices.



wagner-group.com/hea-protip

Standard airless technology



ADVANTAGES OF SPRAYING

Are you interested in knowing why spraying is better than using a roller? Efficient processes keep working time and costs to a minimum. Further advantages include an easier way of working, clean transportation of materials to and around the site and the professional image. Technological advantages include the following:

- Time savings: faster paint application than using brushes and rollers
- Even coverage in just one pass
- Direct intake from the paint container
- No cutting-in. Cleanly and easily spray corners and edges

NOZZLES – THE HEART OF THE SPRAYING PROCESS:

No matter which technology you work with, the tip decides the surface quality: They define the spray pattern, atomise the materials, influence the working speed and are critical for the delivery rate that the pump must achieve. Top-quality tips are essential for a high-quality surface finish in line with your professional standards.

The nozzle angle determines the width of the spray angle, e.g. in this case 50°.

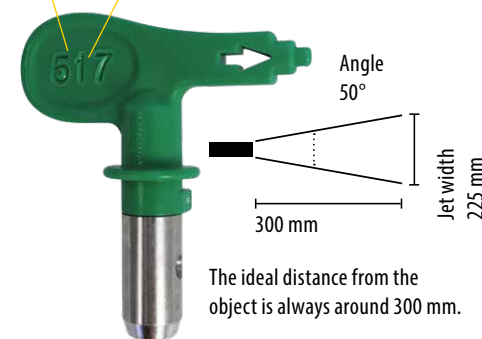

The bore diameter (in this case, 0.017 inch) determines the flow volume and thus the amount of paint applied.

The ideal distance from the object is always around 300 mm.

QUICK HELP



wagner-group.com/tips-tricks

ACCESSORIES

HOSES

HP hose DN6, 27 MPa, NPSM 1/4", 15 m	9984574
HP hose DN4, 27 MPa, NPS 1/4", 7.5 m	9984573

GUN AND TIP

Airless gun Vector Pro, 1/4", incl. TradeTip 3 nozzle holder, with 4-finger trigger	538040
Airless gun Vector Grip, 1/4", incl. TradeTip 3 nozzle holder, with 4-finger trigger	538043
TradeTip 3 nozzles	0553XXX
HEA ProTip nozzles	0554XXX
Nozzle holder, G-thread 7/8", for TradeTip 3 nozzles	0289390

OTHERS

Nozzle extension, 30 cm, G-thread, with holder without nozzle	556075
Nozzle extension, 15 cm, G-thread, with holder without nozzle	556074
EasyGlide	508619
TipClean	2400214
EasyClean (1L)	2412656



POWERPAINTER 90 Extra

BE UNSTOPPABLE!

POWERPAINTER 90 Extra

Weight	23 kg
Motor output	0,8 kW
Voltage	230 V / 50 Hz
Max. nozzle size	0,019"
Max. operating pressure	200 bar, 20 MPa
Max. delivery rate	1,6 l/min
Max. Viscosity	20.000 mPas
Article number	2401275



More about PowerPainter 90 Extra online:
wagner-group.com/pp90extra

Comfortable: The variably adjustable telescopic handle allows a convenient transport on the construction site and a space-saving storage of the device.

Pressure gauge: Allows the perfect control of pressure in coordination with the material being processed.

Integrated toolbox: Ideal for storing tools and accessories.

DIN 6, 15 m high-pressure hose: for a large radius of action.



Innovative HEA nozzle technology: two nozzle bores, one directly in front of the other, guarantee a perfect spray pattern with high material throughput even in low pressure ranges.

Ergonomic airless gun: for fatigue-free and safe work.

Inlet pusher valve: for a high operating reliability and easy commissioning. Just the press of a finger, and the valve is free

PP 90 EXTRA - FOR SMALL PROJECTS

INNOVATIVE, HIGH-EFFICIENCY AIRLESS TECHNOLOGY (HEA): the HEA ProTip nozzle ensures up to 55% less spray mist and also, thanks to the reduced spray pressure, ensures a longer service life.

EASY PAINT APPLICATION: noticeably easier paint application is made possible by the soft spray pattern and maximum control.

DIRECT SUCTION FROM THE ORIGINAL CONTAINER: The airless paint spray system sucks materials directly out of the paint bucket or varnish container.

PISTON PUMP

Do you mostly work with high-viscosity or filler materials? Then a WAGNER piston pump is the perfect, reliable site companion for you. The high suction power produced by the piston's lifting motion makes it ideal for this type of material.

ADVANTAGES:

- Powerful suction
- Better delivery capacity with high viscosity materials
- Less sensitive to heavily filled materials
- Extra-durable Packing



Mehr zur Technik:
wagner-group.com/technologies

HOW TO SPRAY?

TIP 1: EVEN DISTANCE - APPROX. 30 CM

TIP 2: 90° ANGLE TO THE SURFACE

TIP 3: CONSISTENT SPRAYING SPEED

TIP 4: 30% PAINT OVERLAP

TIP 5: THE RIGHT SEQUENCE - CORNERS AND EDGES FIRST THEN LARGE SURFACES

TIP 6: START MOVING THE GUN BEFORE SPRAYING

RECOMMENDED USE

MATERIALS:

Water and solvent-based lacquers, lacquer paints, oils, separating agents

Synthetic resin varnishes, PVC lacquers, 2K lacquers

Primers, fillers

Fire protection, rust protection paints

Emulsion and latex paints, adhesives, sealants

OBJECT SIZE:



SPRAYGUIDES

This is where you'll find answers about how to set up your device to suit the material and which paints and lacquers give the best spray results with your WAGNER model.
sprayguide.wagner-group.com

